

Autonics PHOTOELECTRIC SENSOR BA SERIES

M A N U A L



Thank you very much for selecting Autonics products.
For your safety, please read the following before using.

Caution for your safety

- ※Please keep these instructions and review them before using this unit.
- ※Please observe the cautions that follow;
 - Warning** Serious injury may result if instructions are not followed.
 - Caution** Product may be damaged, or injury may result if instructions are not followed.
- ※The following is an explanation of the symbols used in the operation manual.
 - ⚠ Caution: Injury or danger may occur under special conditions.

Warning

- In case of using this unit with machinery(Ex: nuclear power control, medical equipment, ship, vehicle, train, airplane, combustion apparatus, safety device, crime/disaster prevention equipment, etc) which may cause damages to human life or property, it is required to install fail-safe device.
It may cause a fire, human injury or damage to property.
- Do not disassemble or modify this unit. Please contact us if it is required.
It may cause electric shock or a fire.

Caution

- This unit shall not be used outdoors.
It might shorten the life cycle of the product or cause electric shock.
Use this product inside only. Do not use the product outdoors or location subject to temperatures or humidity outside.(Example: rain, dirty, frost, sunlight, condensation, etc.)
- Do not use this unit in place where there is flammable or explosive gas.
It may cause a fire or explosion.
- Please observe the rated voltage and do not supply AC power.
It may cause damage to this unit.
- Please check the polarity of power and wrong wiring.
It may cause damage to this unit.
- Do not use this unit in place where there is vibration or impact.
It may cause damage to this unit.
- In cleaning the unit, do not use water or an oil-based detergent.
It may cause electric shock or a fire.

Ordering information

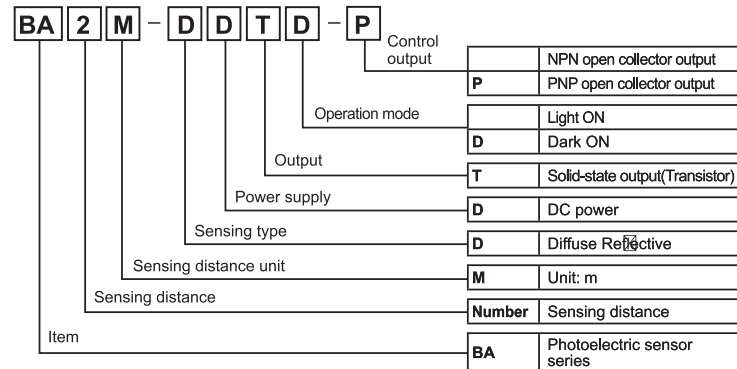

Dimensions

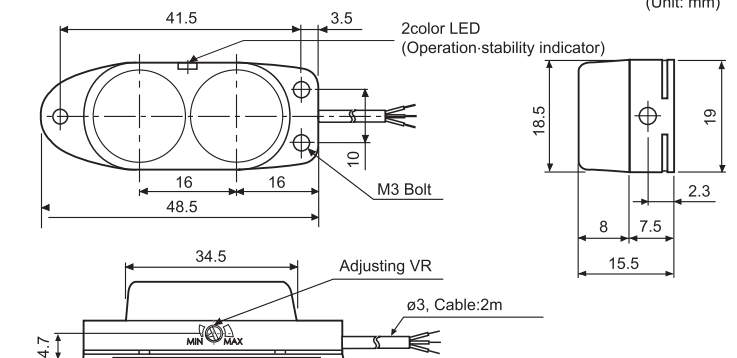

※The above specifications are subject to change and some models may be discontinued without notice.

Specification

Model	NPN output	BA2M-DDT	BA2M-DDTD
	PNP output	BA2M-DDT-P	BA2M-DDTD-P
Sensing type	Diffuse Reflective		
Sensing distance	2m(Non-glossy white paper 200×200mm)		
Sensing target	Translucent, Opaque materials		
Hysteresis	Max. 20% at sensing distance		
Response time	Max. 1ms		
Power supply	12-24VDC ±10% Ripple(P-P) Max. 10%		
Current consumption	Max. 15mA(max. 30mA when the output is ON)		
Light source	Infrared LED(850nm)		
Sensitivity adjustment	Light ON		Dark ON
	Dark ON		Light ON
Control output	NPN or PNP open collector output •Load voltage: Max.26.4VDC •Load current: Max.100mA •Residual voltage - NPN: Max.1V, PNP: Max. 2.5V		
Protection circuit	Reverse polarity protection, output short-circuit protection		
Receiver	Photo IC		
Indicator	Operation: Red, stability: Orange(Light On), Green(Dark On)		
Insulation resistance	Min. 20MΩ(500VDC megger)		
Noise strength	±240V the square wave noise(pulse width:1μs) by the noise simulator		
Dielectric strength	1,000VAC 50/60Hz for 1minute		
Vibration resistance	1.5mm amplitude at frequency of 10 ~ 55Hz in each of X, Y, Z directions for 2 hours		
Shock resistance	100m/s ² in X, Y, Z directions for 3 times		
Environment	Ambient illumination	Sunlight: Max.11,000lx, Incandescent lamp: Max.3,000lx(Receiver illumination)	
	Ambient temperature	-25 to 55°C, Storage: -25 to 70°C	
	Ambient humidity	35 to 85%RH, Storage: 35 to 85%RH	
Protection	IP64(IEC standards)		
Material	Case: ABS, Sensing part: PC, Indicator: PC, VR: IXEF		
Cable	ø3mm, 3-wire, Length: 2m(AWG24, Core diameter: 0.08mm, Number of cores: 40, Insulator diameter: ø1mm)		
Accessory	VR adjustment driver		
Approval	CE		
Weight	Approx. 50g		

※The temperature or humidity mentioned in Environment indicates a non freezing or condensation environment.

Control output circuit diagram

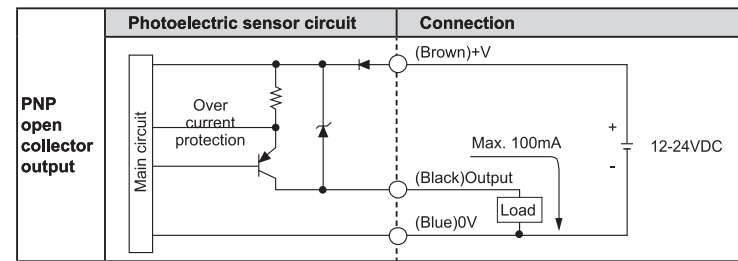
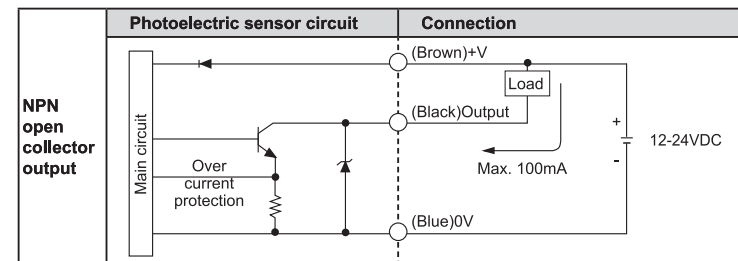

Connection

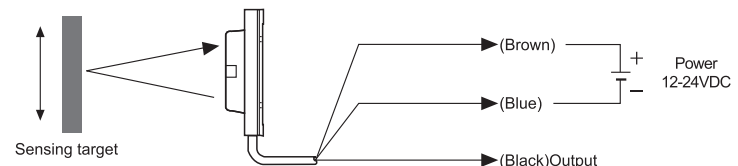

Detecting distance against the target size

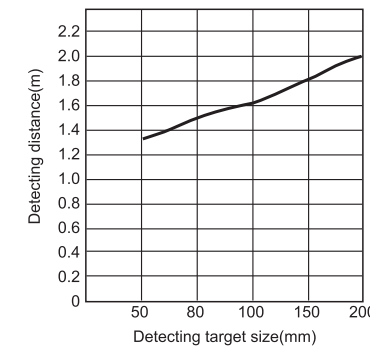

※It shows the change of detecting distance by size of targets. Standard targets: □ 200×200mm non-glossy white paper.

Detecting distance against the target color

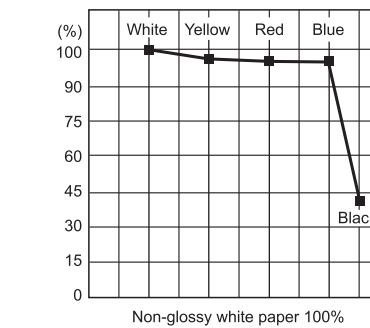

※It shows the rate of detecting distance by color of targets.

Operation mode

If the control output terminal is short-circuit or over current than the rated current flows the unit, the sensor does not operate normally by protection circuit.

Light ON

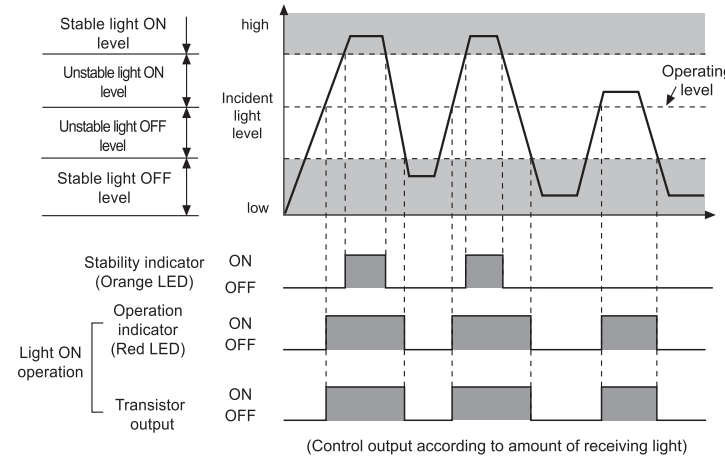

Dark ON

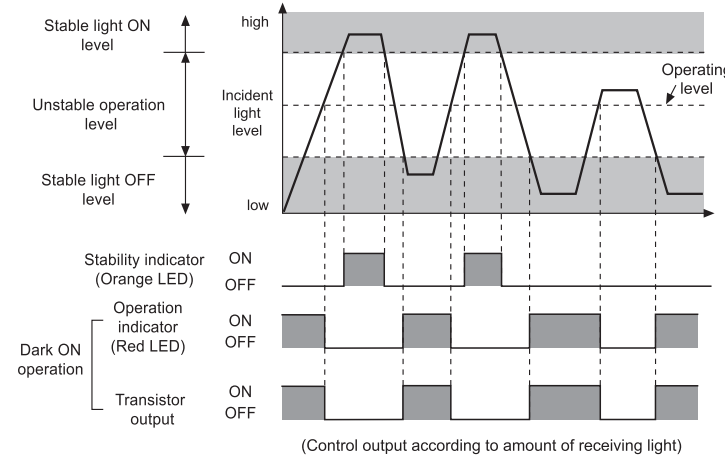

Mounting & Adjustment

Please check wiring after setting the target and supply the power to this sensor.

Optical axis adjustment

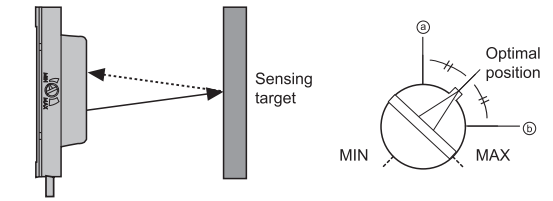

Mount this unit at center position where operation LED turns on as moving the unit toward right or left, up or down

Adjustment

- When sensing the object, set the sensitivity adjustment in stable Light ON area (orange: Light On, Green: Dark On) as shown 'operation mode chart'.
 - The sensitivity should be adjusted depending on a sensing target or mounting place.
 - Set the target at a position to be detected by the beam, then turn the adjuster until position ① where the indicator turns on from min. position of the adjuster.
 - Take the target out of the sensing area, then turn the adjuster until position ② where the indicator turns on. If the indicator does not turn on, Max. position ③.
 - Set the adjuster at the center of two switching position ①, ②.
- ※The sensing distance indicated on specification chart is for 200 X 200mm of non-glossy white paper. Be sure that it can be different by size, surface and gloss of target.

Caution for using

- Intercept a strong source of light as like sunlight, spotlight within inclination angle range of photoelectric sensor.
- The photoelectric sensor may cause malfunction under the fluorescent lamp light, so be sure to use cut-off light with panel.
- When more than two sensors are installed adjacently, it can be occurred malfunction by light beam from the other target. So it must be installed at an enough interval.
- If photoelectric sensor is installed at flat part, it might cause malfunction by reflection light from flat part. Be sure to put space between photoelectric sensor and ground.
- When wire the photoelectric sensor with high voltage line, power line in the same conduit, it may cause malfunction or mechanical trouble. Therefore please wire separately or use different conduit.
- Avoid installing the unit as following place.
Corrosive gas, oil or dust, strong flux, noise, sunlight, strong alkali, acid.
- In case of connect DC relay as inductive load to output, please remove surges by using diode or varistor.
- The photoelectric sensor cable shall be used as short as possible, because it may cause malfunction by noise through the cable.
- When it is stained by dirt at lens, please clean the lens with dry cloth, but don't use an organic materials such as alkali, acid, chromic acid.
- When use switching power supply as the source of supplying power, F.G. terminal shall be good earth ground and condenser for removing noise shall be installed between 0V and F.G. terminal.

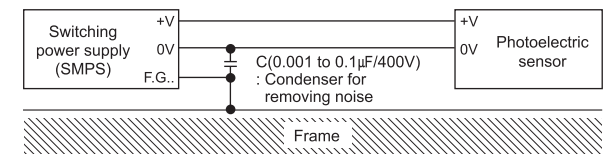

Installation environment

- ①It shall be used indoor.
- ②Altitude Max. 2,000m.
- ③Pollution Degree 3.
- ④Installation Category II

※It may cause malfunction if above instructions are not followed.

Major products

- Photoelectric sensors
- Fiber optic sensors
- Door sensors
- Door side sensors
- Area sensors
- Proximity sensors
- Pressure sensors
- Rotary encoders
- Connector/Sockets
- Switching mode power supplies
- Control switches/Lamps/Buzzers
- I/O Terminal Blocks & Cables
- Stepper motors/drivers/motion controllers
- Graphic/Logic panels
- Field network devices
- Laser marking system(Fiber, CO₂, Nd:YAG)
- Laser welding/soldering system
- Temperature controllers
- Temperature/Humidity transducers
- SSR/Power controllers
- Counters
- Timers
- Panel meters
- Tachometer/Pulse(Rate)meters
- Display units
- Sensor controllers

Autonics Corporation
http://www.autonics.com

Satisfiable Partner For Factory Automation

HEAD QUARTERS:
18, Bansong-ro 513beon-gil, Haendae-gu, Busan, Korea

OVERSEAS SALES:
#402-404, Bucheon Techno Park, 655, Pyeongcheon-ro, Wonmi-gu, Bucheon, Gyeonggi-do, Korea
TEL: 82-32-610-2730 / FAX: 82-32-329-0728
E-mail: sales@autonics.com