

Sewatec/Sewabloc – Waste Water Pump

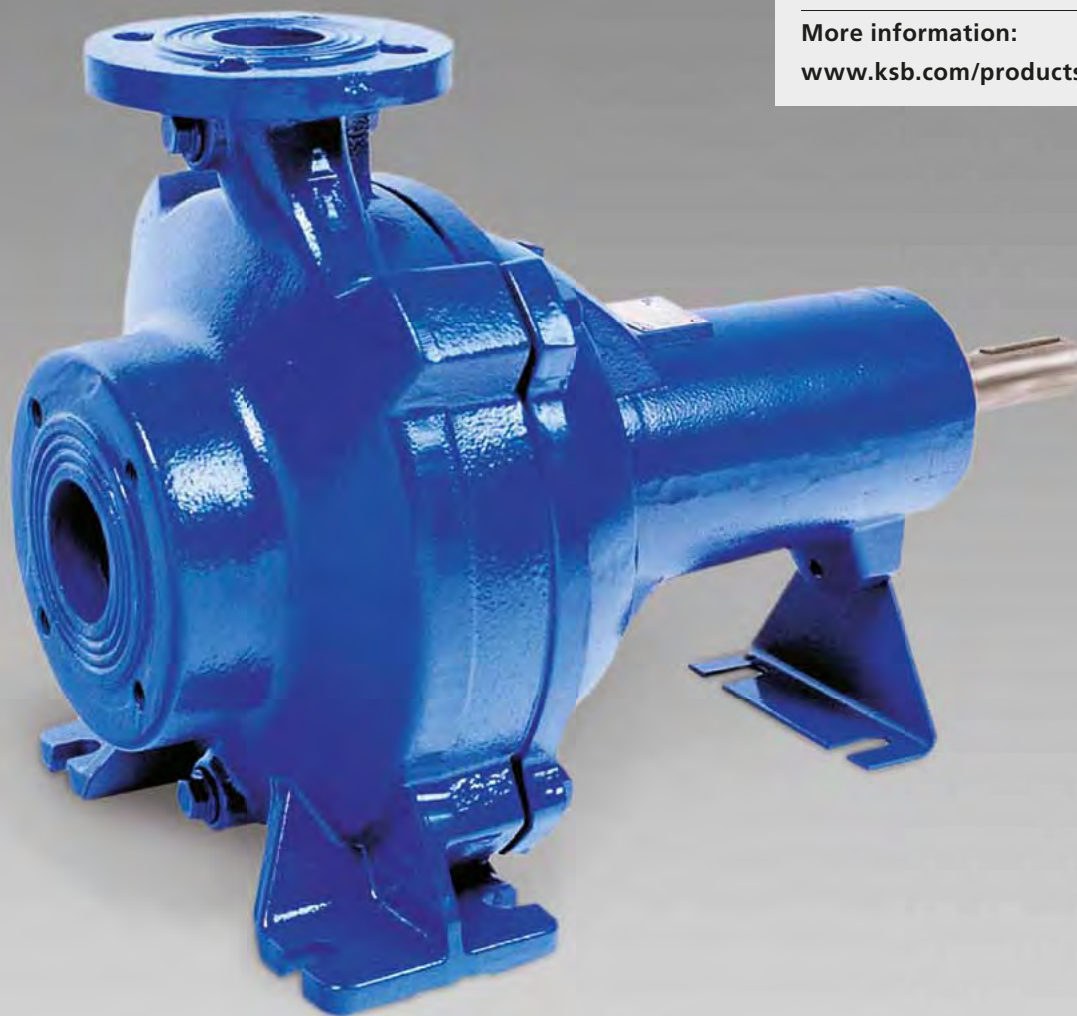

Applications:

- Waste water transport
- Waste water treatment
- Sludge treatment
- Storm water transport

More information:

www.ksb.com/products

Sewatec/Sewabloc – Waste Water Pump

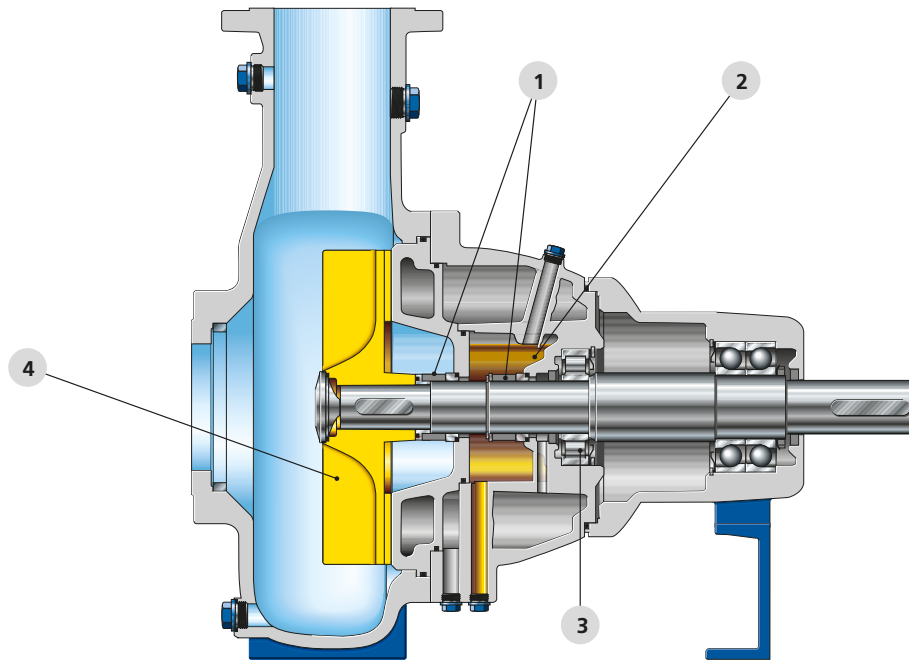

1 High operating reliability

Double-acting mechanical seal in tandem arrangement with oil reservoir seals off the pumped fluids.

2 Cost reduction

Standardised components are interchangeable within the entire Amarex KRT submersible motor pump series, so spare parts inventories can be optimised.

3 Low-maintenance design

Grease-packed rolling element bearings sealed for life.

4 Variable hydraulic system

Impellers and casing optimised for handling waste water.

Variable Installation type

see below

Impellers



Type F



Type E



Type K



Type D

Technical data

Sizes	Up to 700
Capacity	Up to 2,775 l/s
Head	Up to 95 m
Discharge pressure	Up to 10 bar
Temperature	Up to +70 °C

Installation type options

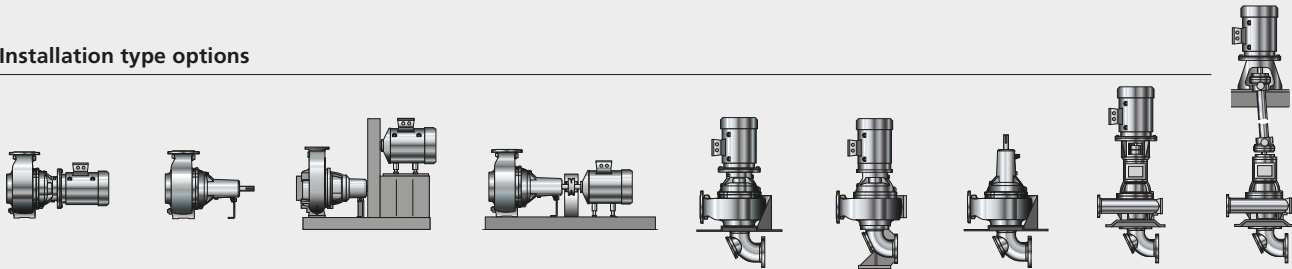

ДП «Ліаг Технік Сервіс Україна»
 61035, г. Харків, ул. Каштановая, 2
 тел.: (057) 756-24-42, 721-32-46, 721-32-45
 E-mail: kharkov@liagtechnik.com.ua
 Сайт: www.liag.prom.ua